

iC

%RH

Series MR13



BASIC FEATURES

- 3-channel controller, 3-channel input, 3-channel setting and simultaneous 3-channel display are possible
- Accuracy: $\pm (0.3\% \text{ FS} + 1 \text{ digit})$
- Follow-up type PV input function
- Follow-up type SV setting function
- Remote/local and DI input function
- Programmable 1 pattern with 9-step function
- Included a new processing system, Expert PID, remarkably improved PID control efficiency; overshoot and undershoot are controlled effectively.
- Interface RS232C/RS485

□ Front Panel Information

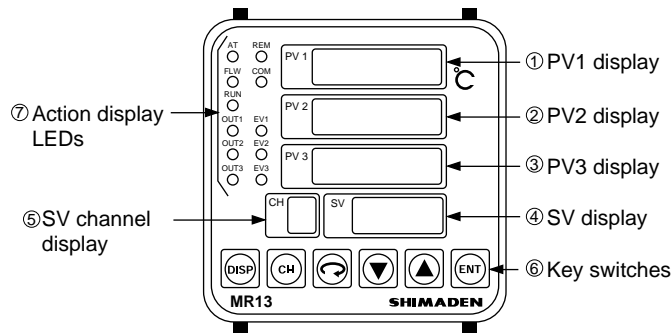

□ Application Example

As the controller is capable of 3-channel input and setting, it is most suitable for zone control. Control of three points is possible by a single controller using three sensors. PV values of three points are displayed simultaneously. The use for zone control such as the upper, middle and lower stages of a batch furnace and the inlet, center and outlet of a tunnel furnace, and for heat control of plastic molds, packing, machines and so forth are highly recommendable.

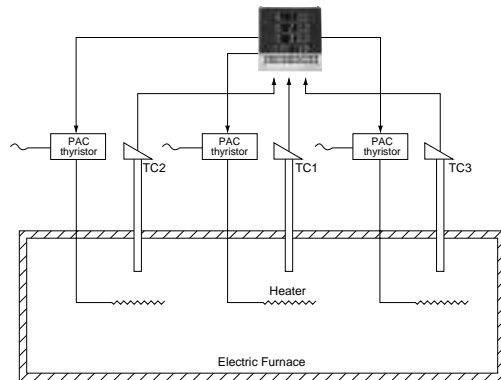

□ Follow-up Type PV Input Function

PV input of CH2 and CH3 can be linked to CH1 input. This function enables the controller to be used for 1-input 2-setting or 1-input 3-setting control.

- Multistage control of heating/cooling

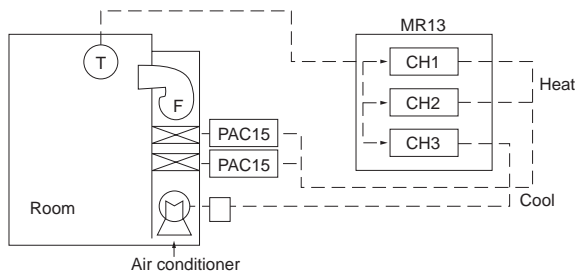

- Control of heating/cooling and humidification/dehumidification

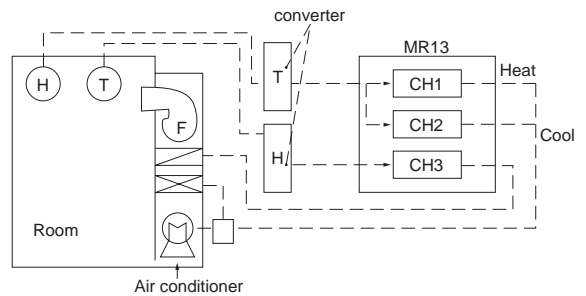

□ Follow-up Type SV Setting Function

As it is possible to make CH2 and CH3 set values follow that of CH1, SVs of these channels can be changed simply by changing CH1 setting. This function is conveniently made use of when temperature levels multiple points are changed or multiple programming functions are used.

□ Use of Expert PID Reduces Overshoot

Higher controllability has been attained by the use of expert PID which can suppress hunting by overshoot or disturbance.

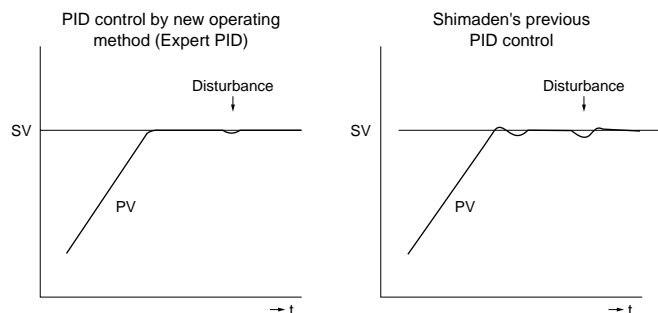

Programming Function

With the addition of the programming control function, it has become possible to carry out zone control of furnaces for china, ceramics, etc., which can be made in an ascending pattern of one pattern with nine steps maximum.

* Program control of 1 pattern with 9 steps maximum

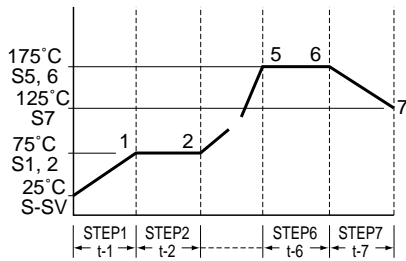

- * Step execution time: 1-9999 minutes
- * The number of executions: 1-9999 times
- * Either PV start or SV start selectable
- * The temporary stop (HLD) function and the step forward (ADV) function are include.

* A program ramp is automatically determined by selecting the temperature and time for each step.

* In the MR13, only CH1 is equipped with the programming function. In case CH2 and CH3 are used for program control, follow-up type SV should be set for each of them.

Remote and DI Input Functions

* The remote or DI input function can be added.

a. DI setting allows the controller to operate in response to an external control (non-voltage contact or open collector) signal.

- * RUN/RST (during program control)
- * HLD (during program control)
- * ADV (during program control)

b. Remote setting of an SV value by means of an external analog signal is possible as per the below drawing nos. 1 and 2.

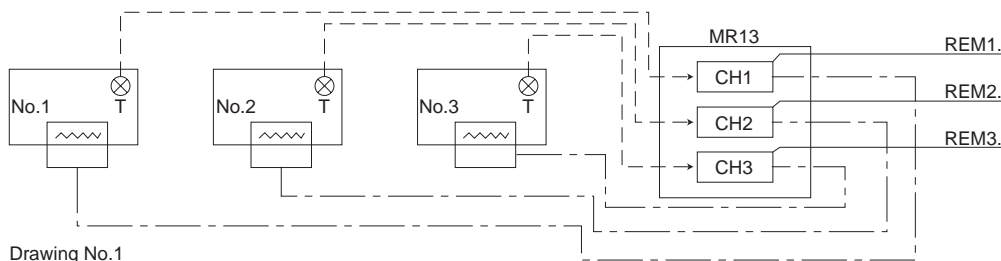

Drawing No.1

c. Simple cascade control by remote setting

* When CH1 control output is made remote SV of CH2, a single MR13 controller can carry out cascade control.

* Select control output (OUT) from CH1 transmission signals (SV, PV and OUT) and input it to the remote terminal of CH2 instead of inputting the control output directly to the remote SV of CH2.

This raises the resolution of CH1 control output so that control characteristics can be improved.

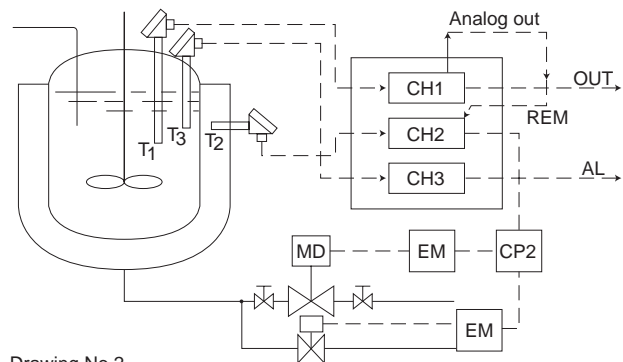

Drawing No.2

Event Function

* Three points are available for event outputs.

* Event output selected from the list of Events shown on page 6 can be assigned to EV1, EV2 and EV3.

Communication Function

For the MR13 series controllers, there are two types of communication interface, RS232C and RS485. Each allows a personal computer, etc., to set and read data of the MR13 series using signals based on EIA standards.

<p>Display</p> <ul style="list-style-type: none"> • LED display: PV display 7-segment LED green 4 digits 3 channels to be displayed individually. SV display 7-segment LED orange 4 digits CH display 7-segment LED orange 1 digit • Action display LED: Control output display: 3 - OUT1, OUT2, OUT3 Auto tuning: 1 - AT Follow type SV display: 1 - FLW Program RUN: 1 - RUN Event output display: 3 - EV1, EV2, EV3 Remote input display: 1 - REM Communication display: 1 - COM ±(0.3%FS + 1 digit) Standard accuracy • Display accuracy: ±(0.3%FS + 1 digit) Standard accuracy • Temperature range in which accuracy is maintained: 23°C±5°C • Display resolution: Depends on measuring range (0.001, 0.01, 0.1, 1) • Sampling cycle: 0.5 seconds • Measured value display range: -10% to 110% of measuring range <p>Setting</p> <ul style="list-style-type: none"> • Setting: By 6 front key operation • Setting range: Same as measuring range • Higher/lower limit setting limiter: Higher and lower limits to be set separately; free within measuring range (Lower limit < higher limit) • Follow type SV setting: SV of CH2 or CH3 can be set to follow CH1 (deviation setting) (on condition that measuring range of CH2 or CH3 is the same as that of CH1.) <p>Input</p> <ul style="list-style-type: none"> • Input type has to be the same for 3 channels (measuring range can be selected individually). • Thermocouple: B, R, S, K, E, J, T, N, PL II, WRe5-26, {L, U (DIN43710)} (Multiple input, multiple range. Refer to measuring range code table.) External resistance: 100Ω maximum Input impedance: 500kΩ minimum Burnout: Standard feature (up scale) Cold junction temperature compensation accuracy: ±2.0 °C (5~45 °C) • R.T.D.: JIS Pt100/JPt100 3-wire type (Multiple range. Refer to measuring range code table.) Amperage: Approx. 0.25 mA Lead wire tolerable resistance: 5Ω maximum/wire • Voltage: ±10, 0~10, 0~20, 0~50, 10~50, 0~100mV DC, or ±1, 0~1, 0~2, 0~5, 1~5, 0~10V DC (Multiple input, programmable range. Refer to measuring range code table.) Input impedance: 500kΩ minimum • Current: 4~20, 0~20mA DC (Multiple input, programmable range. Refer to measuring range code table.) Receiving impedance: 250Ω • Sampling cycle: 0.5 seconds • PV bias: ±1999 units • PV filter: OFF, 1~100 seconds • Follow type PV input: PV input of CH2 or CH3 can be set to follow CH1 (deviation setting) (on condition that measuring range of CH2 or CH3 is the same as that of CH1.) 	<ul style="list-style-type: none"> • Isolation: Insulated between input and various outputs (not insulated between input and system, remote input and DI input) <p>Control</p> <ul style="list-style-type: none"> • Control mode: Expert PID control with auto tuning function Proportional band (P): OFF, 0.1~999.9%FS (OFF=ON/OFF action) Integral time (I): OFF, 1~6000s (OFF=P, PD action with manual reset) Derivative time (D): OFF, 1~3600s (OFF=P, PI action) Manual reset: ±50.0% ON/OFF hysteresis: 1~999 units • Proportional cycle: 0.5~120.0 seconds (0.5 sec. is unit for setting.) • Control output characteristics: RA/DA selectable (set to RA when shipped) • Output limiter: Higher limit, lower limit 0.0~100.0% (lower limit < Higher limit) • Soft start: OFF, ON (Fixed to 10 sec.; Valid when power is turned on, RTS → RUN, and when returned from scaleover.) <p>Control output/rating</p> <ul style="list-style-type: none"> • Output specification has to be the same for 3 channels. • Contact output (Y): 1a 240V AC 2.5A/resistive load • Current output (I): 4~20mA, 0~10mA DC/ load resistance 600Ω maximum. • SSR drive voltage output (P): 15V±3V DC/ Load current 20mA maximum • Voltage output (V): 0~10V DC/ Load current 2mA maximum • Operation output updating cycle: 0.5 second • Isolation: Insulated between control output and system and input (not insulated between control output I, P or V and analog output) <p>Event output (optional)</p> <ul style="list-style-type: none"> • Number of outputs: 3 -EV1, EV2, EV3 (Selectable from CH1, CH2 and CH3, individual setting, individual output) • Output rating: Contact output 1a (common) 240V AC / 1A (resistive load) • Setting: Individual setting 0) NON: Not assigned 1) DEV: Higher limit deviation value alarm 2) DEV: Lower limit deviation value alarm 3) DEV: Higher/lower limit value alarm in case SV is out of measuring range 4) DEV: Higher/lower limit value alarm in case SV is within measuring range 5) PV: Higher limit absolute value alarm 6) PV: Lower limit absolute value alarm 7) SO: ON upon scaleover 8) RUN: ON during program RUN 9) END: ON for 1 sec. upon termination of program 10) STEP: ON for 1 sec. upon termination of program step • Hysteresis: 1~999 units (when DEV or PV has been selected) • Standby action: Selectable (when DEV or PV has been selected) • Action delay time: OFF, 1~9999 seconds (when DEV or PV has been selected) • Isolation: Insulated between alarm output and various inputs/outputs and system
---	---

Remote setting (optional, selectable between this function and DI)

- Setting signal: 1~5V, 0~10V, 4~20mA
- Setting range: Same as measuring range
- Accuracy of setting: $\pm(0.3\%FS + 1)$ digit
- Channel for setting: Selectable from CH1, CH2 and CH3
- Remote scaling: Within measuring range (inverted scaling possible)
- Remote bias: -1999~5000 units
- Remote filter: OFF, 1~100 seconds
- Sampling time: 0.5 second
- Isolation: Insulated between remote input and various outputs (not insulated from system and various inputs)

External control input (DI) (optional, selectable between this function and remote setting)

- Number of input point: 1
- Input rating: Non-voltage contact, open collector input (about 5V/0.4mA DC impress) NON, FLW (follow type SV), RST/RUN, HLD and ADV
- Action type:
- Isolation: Insulated between DI input and various outputs (not insulated from system and various inputs)

Program (optional)

- Registrable pattern: 1
- Number of steps: 9 maximum
- Program setting range
 - Level: Same as measuring range
 - Time: 1~9999 minutes/step
 - Ramp: To be set automatically according to level and time
- Number of executions: 9999 maximum
- PID output limiter: To be set selectively from 3 types of PID & output limiter
- External control input: DI/non-voltage 1 point (RUN/RST, HLD, ADV)
- Action status output: RUN, END and STEP to be selectively output to event output
- CH2 and CH3 in SV follow setting: Program to be executed by making CH2 or CH3 deviation-follow to pattern set in CH1 in SV follow setting. Not in SV follow setting, program is executed in FIX mode.
- Additional functions: Temporary suspension (HLD), carry-forward (ADV), PV start

Analog output (optional, selectable between this function and communication)

- Number of output: 1
- Output types: Selectable from CH1_PV, CH2_PV, CH3_PV, CH1_SV, CH2_SV, CH3_SV, CH1_OUT, CH2_OUT and CH3_OUT
- Output rating: 0~10mV DC/Output impedance 10 Ω maximum
0~10V DC/Load current 1mA maximum
4~20mA DC/Load resistance 300 Ω maximum
- Output accuracy: $\pm 0.3\%FS$ (to displayed value)
- Output resolution: Approx. 1/8000
- Output updating cycle: 0.5 seconds
- Output scaling: Within measuring range (inverted scaling possible)
- Isolation: Insulated between analog output and various inputs and system (not insulated between analog output and control outputs I, P and V)

Communication (optional, selectable between this function and analog output)

- Communication type: RS-232C, RS-485
- Communication system: Half duplex start-stop synchronous system
- Communication speed: 1200, 2400, 4800, 9600, 19200bps
- Data format: 7 bits, 8 bits, no parity, even parity selectable

- Communication address: 1~99
- Communication code: ASCII code
- Communication protocol: Shimaden standard protocol
- Communication format: Control code selectable, BCC check arithmetic system selectable
- Isolation: Insulated between communication signal and system/input/output
- Others: Meets the EMC standards with an additional clamp filter (E04SR301334, SEIWA Information Systems Co.,LTD)

Others

- Data storage: By non-volatile memory (EEPROM)
- Ambient temperature/humidity ranges: -10~+50°C/below 90% RH (on condition that there is no dew condensation)
- Temperature for storage: Between -20 and +65 °C
- Power voltage: 100V~260V AC $\pm 10\%$ (50/60 Hz)
- Power consumption: 18VA maximum
- Input noise removal ratio: Normal mode 45 dB minimum (50/60 Hz)
Common mode 140 dB minimum (50/60 Hz)
- Applicable standard
 - Safety: IEC1010-1 and EN61010-1
 - EMC: EN61326
- Insulation resistance: Between input/output terminals and power terminal: 500V DC 20M Ω minimum
Between input/output terminals and protective conductor terminal: 500V DC 20M Ω minimum
- Dielectric strength: 1 minute at 2300V AC between input/output terminals and power terminal (inductive current 5mA)
1 minute at 2300V AC between power terminal and ground terminal (inductive current 5mA)
- Protective structure: Only front panel has simple dust-proof and drip-proof structure
- Material: PPO resin molding (equivalent to UL94V-1)
- External dimensions: 96 x 96 x 110 mm (Panel depth: 100 mm)
- Mounting: Push-in panel (one-touch mount)
- Panel cutout size: H92 x W92 mm
- Weight: Approx. 420 g

ITEMS		CODE		SPECIFICATIONS	
SERIES	MR13-			MPU-Based 3 Channel Auto-Tuning PID Controller DIN 96 × 96mm	
INPUT	1			Thermocouple B, R, S, K, E, J, T, N, PLII, WRe5-26, U, L	Multi-input Multi-range
	2			R.T.D. Pt100 / JPt100	Multi-range
	3			Voltage (mV) -10-10, 0-10, 0-20, 0-50, 10-50, 0-100mV DC	Multi-input Programmable Range
	4			Current (mA) 0-20, 4-20mA DC	
	6			Voltage (V) -1-1, 0-1, 0-2, 0-5, 1-5, 0-10V DC	
CONTROL OUTPUT	Y1-			Contact: Proportional Cycle 0.5-120.0 sec. Contact capacity: 240V AC 2.5A / resistive load	
	I1-			Current: 4-20, 0-10mA DC Load resistance: 600Ω max.	
	P1-			SSR drive voltage: Proportional Cycle 0.5-120.0 sec. Output rating: 15V±3V DC / 20mA max.	
	V1-			Voltage: 0-10V DC Load current: 2mA max.	
PROGRAM FUNCTION (OPTION)	N			None	
	P			1 Pattern, 9 step	
EVENT OUTPUT (OPTION)	0			None	
	1			Contact (1a common): 240V AC 1A / resistive load EV1, EV2, EV3 / 3 Point	
REMOTE OR DI INPUT (OPTION)	00			None	
	04			4-20mA DC Receiving resistance: 250Ω	
	05			1-5V DC Input resistance: 500kΩ min.	
	06			0-10V DC Input resistance: 500kΩ min.	
	51			DI Non-Voltage Contact, Open Collector Input	
ANALOG OUTPUT OR COMMUNICATION FUNCTION (OPTION)	00			None	
	03			Voltage 0-10mV DC, Output resistance: 10Ω	
	04			Current 4-20mA DC, Load resistance: 300Ω max.	
	06			Voltage 0-10V DC, Load current: 1mA max.	
	15			RS-485	
	17			RS-232C	
REMARKS	0			Without	
	9			With (Please consult before ordering.)	

TYPES OF EVENTS

Event type code table

Code	Event type	Setting range of event set value	Initial value of event set value
OFF	Not assigned		
1	Higher limit deviation value	0~1999 Unit	1999 Unit
2	Lower limit deviation value	0~-1999 Unit	-1999 Unit
3	Out of higher/lower limit ranges	0~1999 Unit	1999 Unit
4	Within higher/lower limit ranges	0~1999 Unit	1999 Unit
5	Higher limit absolute value	Within measuring range	Higher limit value of measuring range
6	Lower limit absolute value	Within measuring range	Lower limit value of measuring range

Code	Event type	Setting range of event set value	Initial value of event set value
7	Scale-over	In the case of scale-over, EV output is continued.	
8	Program RUN	EV output is continued while program is in execution.	
9	Program END	EV output is produced for about 1 second upon termination of program.	
10	Program STEP	EV output is produced for about 1 second upon switching steps.	

Note: The above codes from 8 to 10 are selectable only when program option is added.

Input type	Code	Measuring range	Code	Measuring range	
Thermocouple	*1 B	01 0 ~ 1800 °C	15	0 ~ 3300 °F	
	R	02 0 ~ 1700 °C	16	0 ~ 3100 °F	
	S	03 0 ~ 1700 °C	17	0 ~ 3100 °F	
	K	04	-100.0 ~ 400.0 °C	18	-150 ~ 750 °F
		05	0.0 ~ 800.0 °C	19	0 ~ 1500 °F
		06	0 ~ 1200 °C	20	0 ~ 2200 °F
	E	07 0 ~ 700 °C	21	0 ~ 1300 °F	
	J	08 0 ~ 600 °C	22	0 ~ 1100 °F	
	*2 T	09 -199.9 ~ 200.0 °C	23	-300 ~ 400 °F	
	N	10 0 ~ 1300 °C	24	0 ~ 2300 °F	
	PLII	11 0 ~ 1300 °C	25	0 ~ 2300 °F	
	WRe5-26	12 0 ~ 2300 °C	26	0 ~ 4200 °F	
	*2 U	13 -199.9 ~ 200.0 °C	27	-300 ~ 400 °F	
	L	14 0 ~ 600 °C	28	0 ~ 1100 °F	
R.T.D.	Pt100 (New) JIS/IEC	31	-200 ~ 600 °C	47	-300 ~ 1100 °F
		32	-100.0 ~ 100.0 °C	48	-150.0 ~ 200.0 °F
		33	-100.0 ~ 300.0 °C	49	-150 ~ 600 °F
		34	-50.0 ~ 50.0 °C	50	-50.0 ~ 120.0 °F
		35	*3 0.0 ~ 50.0 °C	51	0.0 ~ 120.0 °F
		36	0.0 ~ 100.0 °C	52	0.0 ~ 200.0 °F
		37	0.0 ~ 200.0 °C	53	0.0 ~ 400.0 °F
	JPt100 (Old) JIS	38	0.0 ~ 500.0 °C	54	0 ~ 1000 °F
		39	-200 ~ 500 °C	55	-300 ~ 900 °F
		40	-100.0 ~ 100.0 °C	56	-150.0 ~ 200.0 °F
		41	-100.0 ~ 300.0 °C	57	-150 ~ 600 °F
		42	-50.0 ~ 50.0 °C	58	-50.0 ~ 120.0 °F
		43	*3 0.0 ~ 50.0 °C	59	0.0 ~ 120.0 °F
		44	0.0 ~ 100.0 °C	60	0.0 ~ 200.0 °F
45	0.0 ~ 200.0 °C	61	0.0 ~ 400.0 °F		
46	0.0 ~ 500.0 °C	62	0 ~ 900 °F		

Input type	Code	Measuring range
mV	-10 ~ 10	71
	0 ~ 10	72
	0 ~ 20	73
	0 ~ 50	74
	10 ~ 50	75
	0 ~ 100	76
V	-1 ~ 1	81
	0 ~ 1	82
	0 ~ 2	83
	0 ~ 5	84
	1 ~ 5	85
	0 ~ 10	86
mA	0 ~ 20	94
	4 ~ 20	95

Depending on scaling function, you may set measuring range at any value within the following range:
 Scaling range: -1999~9999 count
 Span: 10~5000 count
Note: Lower limit value < Higher limit value

- *1 Thermocouple B: Temperature above 400°C or below 750 °F is excluded from accuracy assurance.
- *2 Thermocouple T, U: Accuracy of temperature between -199.9 and 100.0°C is ±0.5% FS.
- *3 R.T.D.: Accuracy is ±0.3°C (±0.8 °F).

□ The following table shows factory-set measuring range codes:

Input	Standard/rating	Code	Measuring range
1. Thermocouple	JIS K	05	0.0 ~ 800.0°C
2. R.T.D.	JIS Pt100	37	0.0 ~ 200.0°C
3. Voltage	0 ~ 10mV DC	72	0.0 ~ 100.0
4. Current	4 ~ 20mA DC	95	0.0 ~ 100.0
5. Voltage	0 ~ 10V DC	86	0.0 ~ 100.0

EXTERNAL DIMENSIONS

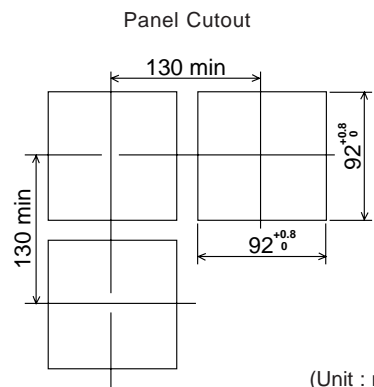
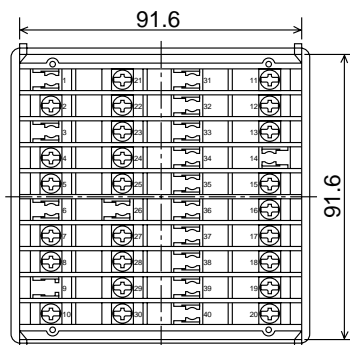
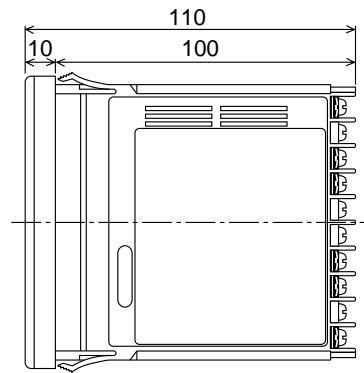
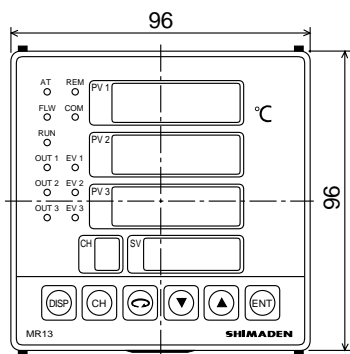

(Unit : mm)

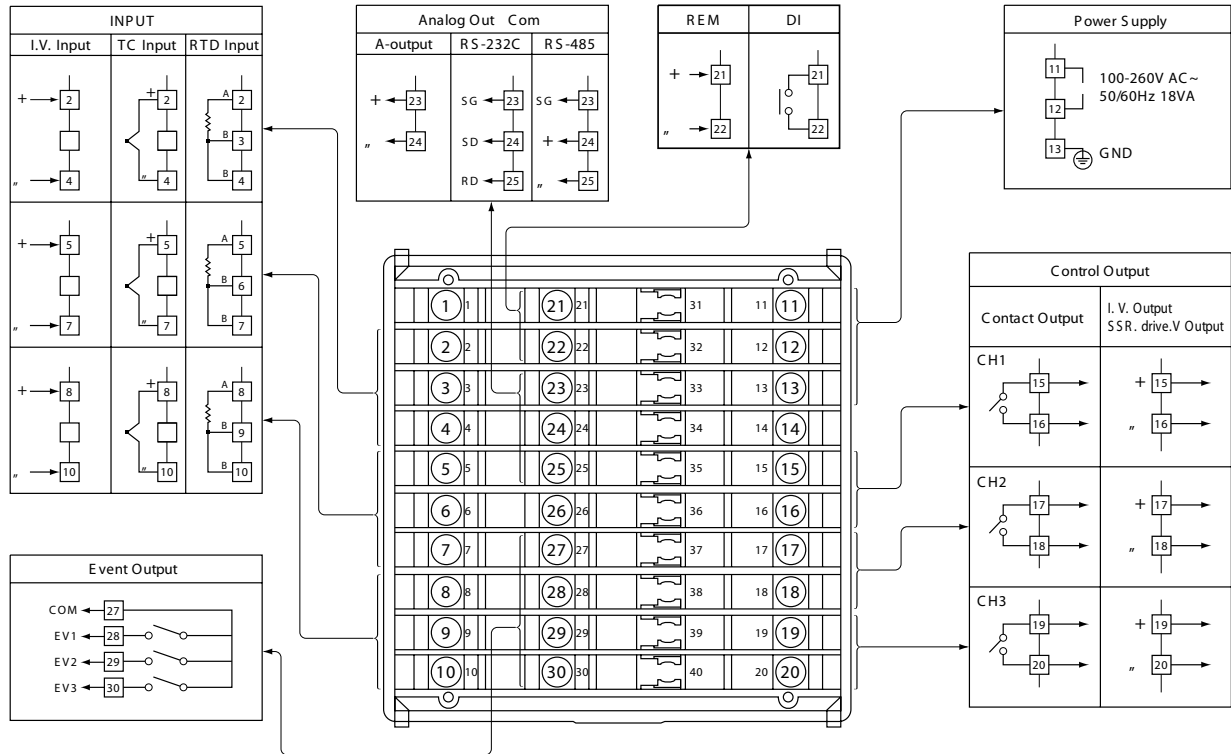

Model	
MR13	SR5301-9

Material/ Appearance: PVC / transparent
Thickness: 1mm

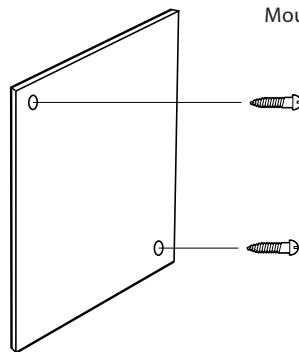

Mounting: 2+B tight pan-head screws
M2.3x6mm

Warning

The MR13 series is designed for the control of temperature, humidity and other physical values of general industrial equipment. (It is not to be used for any purpose which regulates the prevention of serious effects on human life or safety.)

Caution

If the possibility of loss or damage to your system or property as a result of failure of any part of the process exists, proper safety measures must be made before the instrument is put into use so as to prevent the occurrence of trouble.



ISO 9001

DUE TO CONTINUOUS PRODUCT IMPROVEMENT, THE DESIGN AND TECHNICAL SPECIFICATIONS ARE SUBJECT TO CHANGE WITHOUT PRIOR NOTICE.

TASHIKA BOEKI SHOKAI K.K.

1-12, Kaiyo-cho, Ashiya, 659-0035, JAPAN
Tel: + 81-797-23-9035 Fax: + 81-797-23-2105
e-mail: sales@tashika.co.jp URL: www.tashika.co.jp