

SOLAR POWERED REVOLVING LAMP

VM10S TYPE (Φ 105mm)

FEATURES

- ① Built-in solar panel
- ② Needs no electrical wiring
- ③ Automatic solar On/Off switching
- ④ Up to 10 years maintenance free service life
- ⑤ Dust proof and water jet proof: IP55 design
- ⑥ Simulated revolving light without using any motor, thus completely vibration-proof design



DESCRIPTION

Solar powered revolving lamp VM10S is a warning lamp designed for maintenance free service life of up to ten years (capacitor version). This lamp can easily be installed without any electrical wiring thus it can be used at sites where it is difficult to provide electric power supply to work as caution light, hazard light obstruction alert light. Once installed it needs no intervention by any operator and has no running cost.

Built-in solar panel gets charged in sunlight during the day. LED switches on automatically when it gets dark. Capacitor version has longer maintenance free service life. Ni-MH rechargeable battery version needs replacement of battery after three years. Revolving or flashing light function can be selected through an internal switch. On/off switch is also provided when warning light is not required. The lamp continues to get charged even in switched off position.

Lamps intensity is adequate to ensure continuous visibility at night. Lamp enclosure has IP55 class dust and water resistance for outdoor use.

MODEL CODE

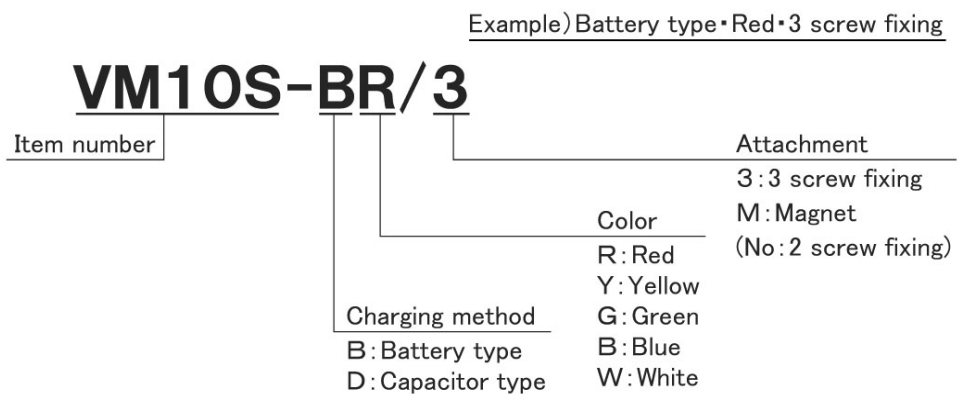

DIMENSIONS

2 screw fixing

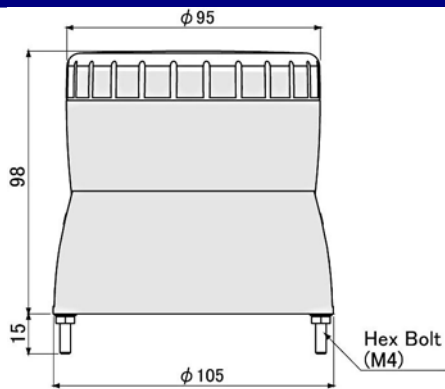

Cap : Polycarbonate
Body : Polycarbonate

3 screw fixing

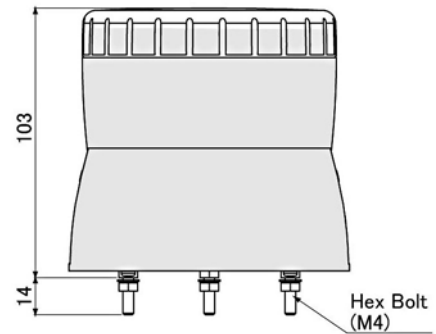

2 screw fixing installation

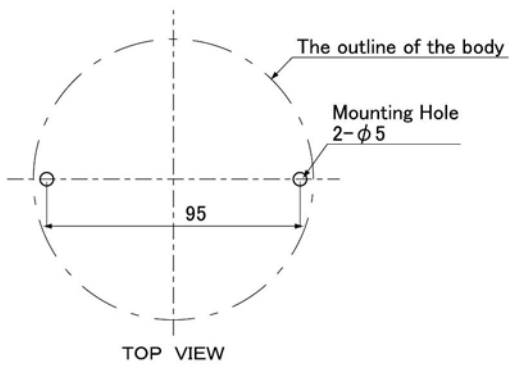

3 screw fixing installation

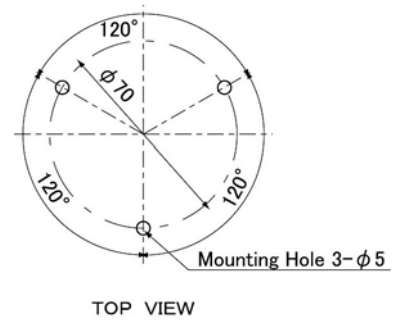

OPTION

Mounting bracket A82710



DUE TO CONTINUOUS PRODUCT IMPROVEMENT, THE DESIGN AND TECHNICAL SPECIFICATIONS
ARE SUBJECT TO CHANGE WITHOUT PRIOR NOTICE

TASHIKA BOEKI SHOKAI K.K.

1-12, Kaiyo-cho, Ashiya-shi, Hyogo 659-0035, JAPAN

Tel: + 81-797-23-9035 Fax: + 81-797-23-2105

e-mail: sales@tashika.co.jp URL: www.tashika.co.jp